

Highly Liquid

MPA

Hardware Revision B

User Manual

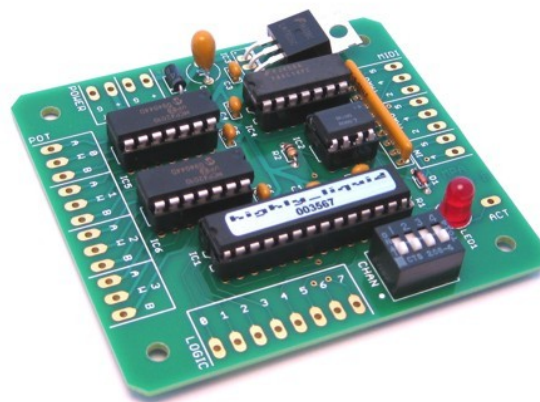

Updated 2010-06-02

Additional documentation available at:

<http://highlyliquid.com/support/>

Table of Contents

1.0 Important Safety Information	2
2.0 Assembly Instructions	2
3.0 Feature Diagram	5
4.0 Mechanical Drawing	6
5.0 Power Supply	7
6.0 MIDI Wiring	8
7.0 Outputs	10
7.1 Electrical Specifications.....	10
7.2 Output Wiring.....	10

1.0 Important Safety Information

To prevent damage to the MPA and connected devices, and to prevent personal injury:

- Carefully follow the assembly instructions. Assembly errors can cause overheating and excess power consumption. The tantalum capacitor contained in the kit may explode if mounted backwards.
- Take reasonable static-control precautions when assembling & handling the kit. This product includes ESD-sensitive parts.
- Use an [appropriate power source](#).
- Do not exceed the [electrical specifications](#) of the MPA logic & potentiometer outputs.

2.0 Assembly Instructions

The MPA consists of a printed circuit board (PCB, Figure 2.1) and several electronic components which must be mounted on the PCB by soldering. Use conventional tin/lead solder or lead-free solder. When soldering, always wear eye protection and work in a well-ventilated area.

Before assembly, examine all of the components in the kit and identify them using the parts list (Table 2-1). Some parts may be packaged separately inside the kit for easier identification.

Follow the assembly instructions for each component in Table 2-1. Location is indicated by the white legend on the PCB. Mount & solder the smallest components first, then proceed with components of increasing size.

Insert parts into the top (legend side) of the board and apply solder to the underside. Masking tape may be used to temporarily hold smaller components in place. After soldering is complete, trim the component leads from the underside of the PCB.

Figure 2.1: MPA PCB

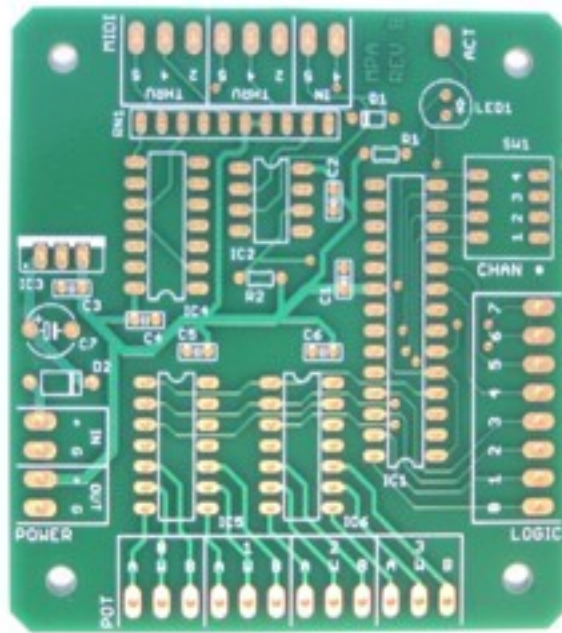

Table 2-1: Parts List















Part	Image	Notes
C1 – C6		0.1µF capacitor. Polarity: none.
C7		Tantalum capacitor. Polarity: the positive lead (marked with a “+”) must match the “+” symbol on the circuit board legend.
D1		Small signal diode. Polarity: dark band on diode must match the white band on the circuit board legend.
D2		Rectifier diode. Polarity: white band on diode must match the white band on the circuit board legend.
IC1		Microcontroller. Mount socket on circuit board first, then insert IC into socket. Notched end must match notch in the circuit board legend.

Table 2-1: Parts List (Continued)

Part	Image	Notes
IC2		Mount socket on circuit board first, then insert IC into socket. End marked with dot must match notch in the circuit board legend.
IC3		Pin 1 is on the left in the photo. Pin 1 must match dot on the circuit board legend.
IC4		7414 hex inverter. Mount socket on circuit board first, then insert IC into socket. Notched end must match notch in the circuit board legend.
IC5, IC6		MCP42xxx digital potentiometer IC. Mount socket on circuit board first, then insert IC into socket. Notched end must match notch in the circuit board legend.
LED1		Polarity: the short lead must match the flat side on the circuit board legend.
R1		1k Ω resistor, marked with the following color bands: brown, black, red, gold.
R2		10k Ω resistor, marked with the following color bands: brown, black, orange, gold.
RN1		Resistor Network. Orientation does not matter.
SW1		DIP Switch. Numbers on switch should match numbers on circuit board legend.

3.0 Feature Diagram

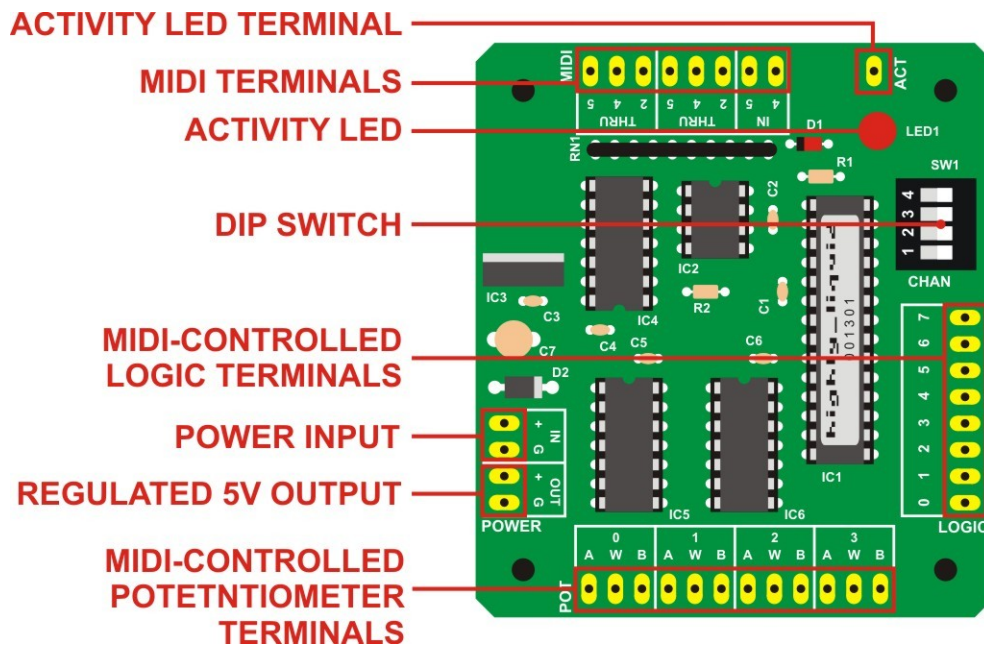

- **Activity LED Terminal:** Attach remote activity indicator LED here.
- **MIDI Terminals:** 1 x Standard MIDI IN port and 2 x Standard MIDI THRU port.
- **Activity LED:** Indicates MIDI activity (see *MPA Firmware User Manual*).
- **DIP Switch:** Optionally sets MIDI channel (see *MPA Firmware User Manual*).
- **MIDI-Controlled Logic Terminals:** 5V CMOS/TTL logic outputs.
- **Power Input:** Connect DC power supply or battery here.
- **Regulated 5V Output:** 5VDC output. Not MIDI-controlled.
- **MIDI-Controlled Potentiometer Terminals:** 3-terminal digital potentiometer outputs.

4.0 Mechanical Drawing

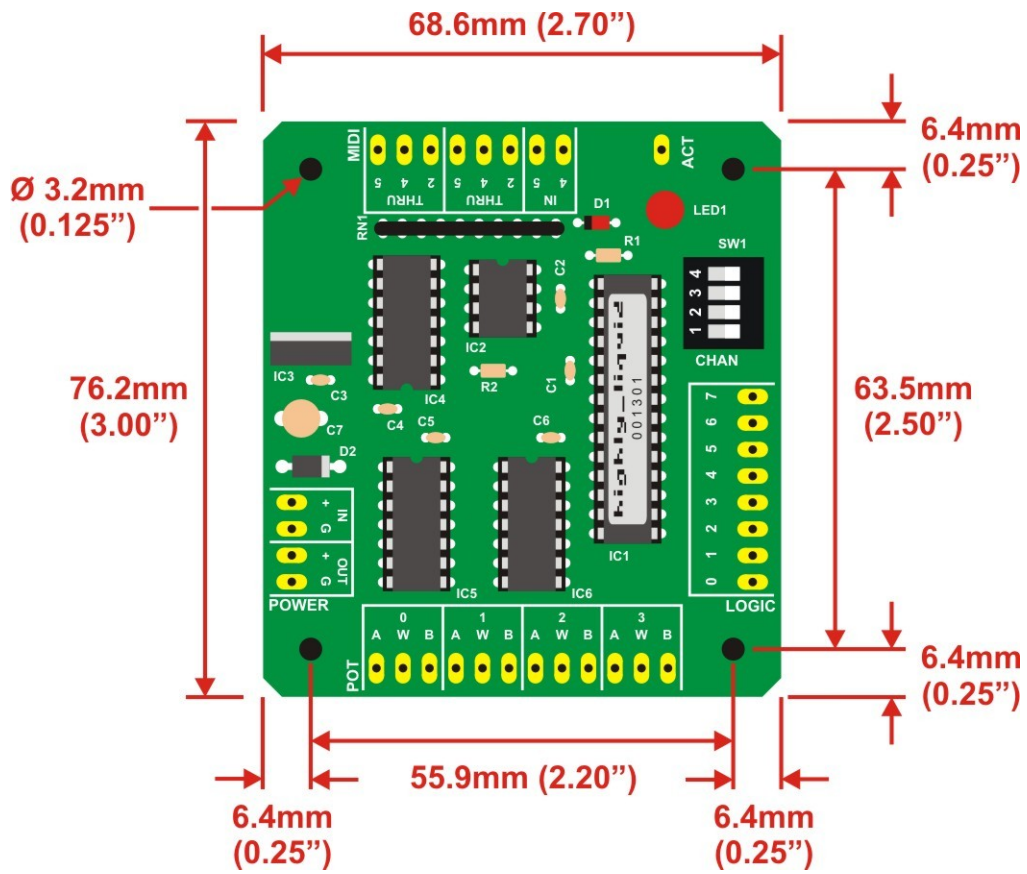

5.0 Power Supply

To operate, the MPA must be connected to a battery or other DC power supply. A “wall adapter” supply with appropriate specifications may be used.

Power supply requirements:

- Maximum output voltage: 12VDC
- Minimum output voltage: 7.5VDC
- Current capacity (**no load on Regulated 5V Output**): 300mA or greater
- Current capacity (**loaded Regulated 5V Output**): Varies with 5V load current

Wire the battery or power supply to the MPA “**POWER IN**” terminals as shown in Figure 5.1. The negative terminal of the battery or power supply is connected to MPA ground, marked “G”. The positive terminal of the power supply or battery is connected to the terminal marked “+”.

The Regulated 5V Output (“**POWER OUT**” terminals) can supply up 500mA of output current. Loading the Regulated 5V Output may cause increased heating of the voltage regulator (IC3). Attach a heat sink to the regulator if necessary. Do not attach a power supply to the “**POWER OUT**” terminals of the MPA.

Figure 5.1: Power Supply Wiring

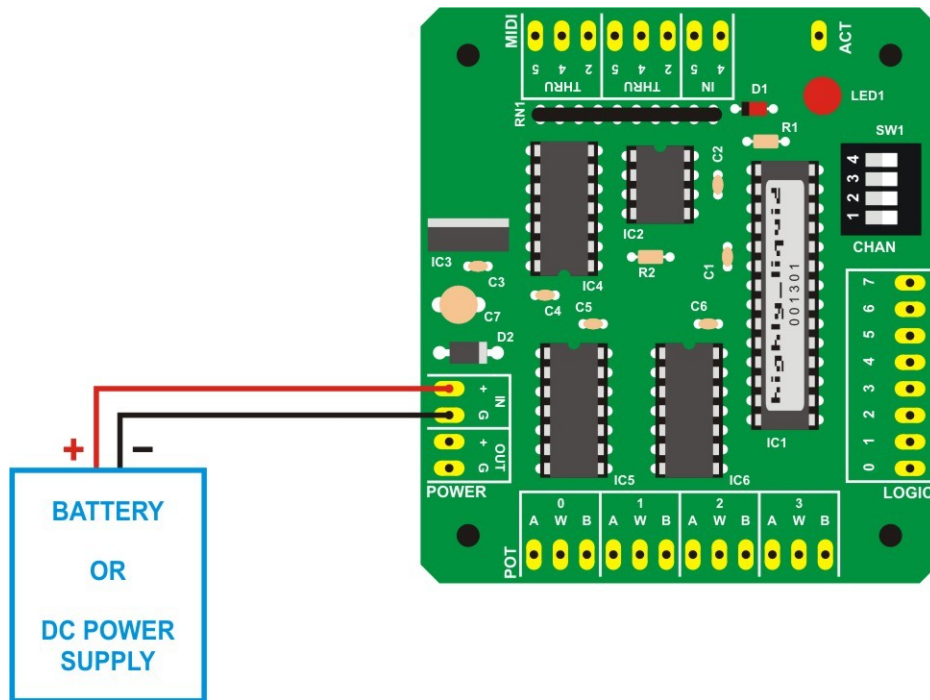

6.0 MIDI Wiring

The MPA features a MIDI IN and dual MIDI THRU ports. The incoming MIDI signal on the MIDI IN port is replicated exactly and output on each of the MIDI THRU ports. Figure 6.1 shows the typical connection to other MIDI devices. Either or both of the THRU ports can be used.

MPA MIDI ports may be wired to MIDI connectors. The MIDI standard specifies a 5-position DIN connector. The MIDI signal is carried by pins 4 & 5. Pin 2 is connected to ground at the OUT or THRU side of the MIDI link, and is left unconnected at the IN side of the link. Pins 1 & 3 are unused. Connector pin numbers are marked on the MPA PCB. See Figure 6.2

Multiple MPA units (or other MIDI devices) can be chained together. For this purpose, MIDI connectors can be bypassed: the THRU port of one unit can be wired directly to the IN port of the next device in the chain. See Figure 6.3.

Figure 6.1: MIDI IN/THRU

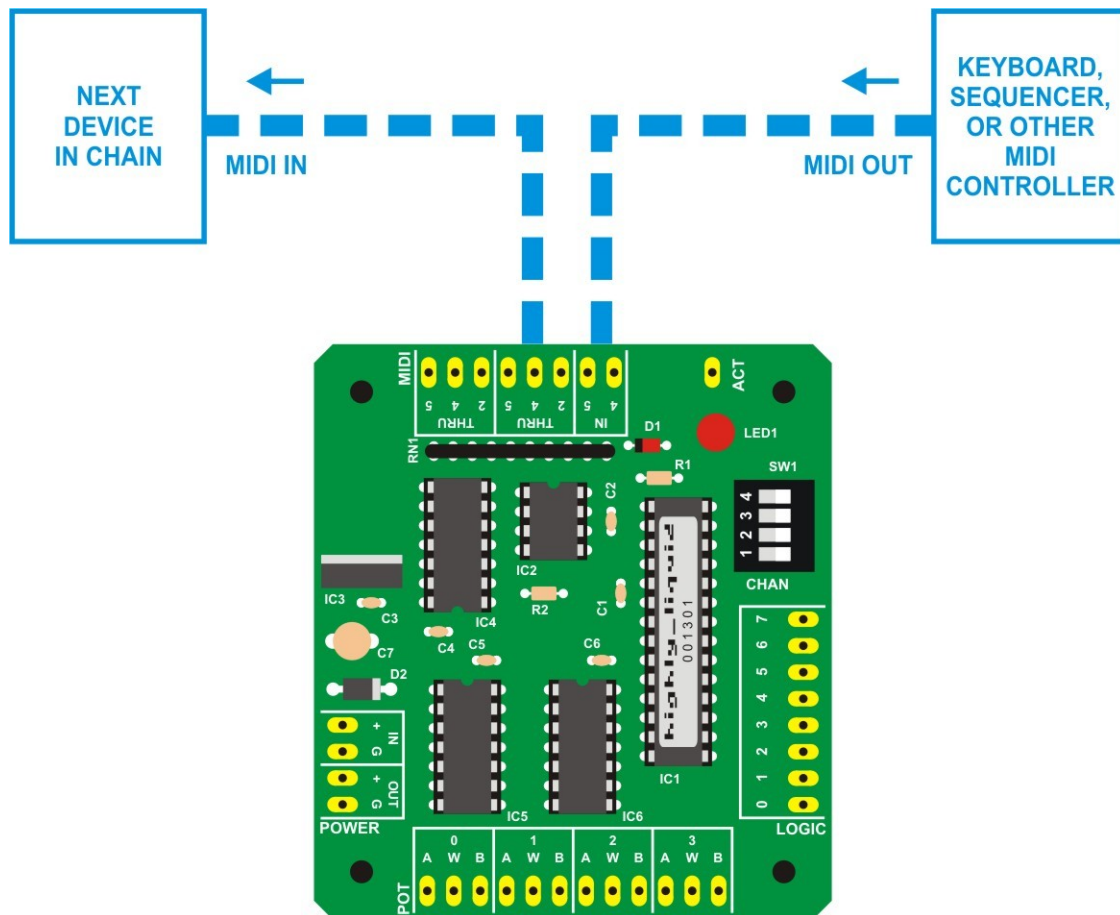

Figure 6.2: MPA MIDI Receptacle Wiring

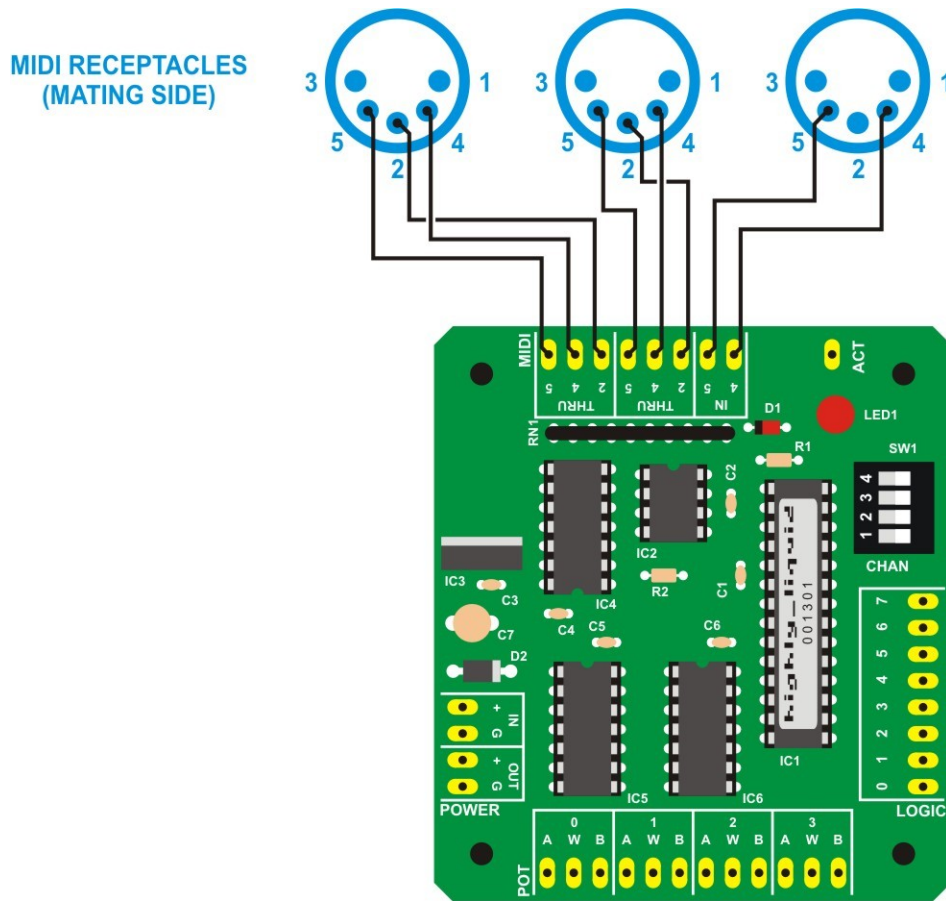
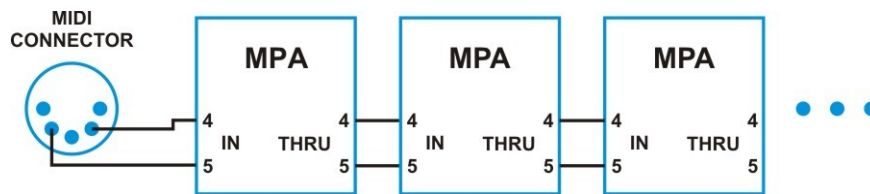

Figure 6.3: Multiple-Device Chain



7.0 Outputs

7.1 Electrical Specifications

MIDI-Controlled Potentiometers

- Nominal variable output resistance: 0 - 10k Ω , 0 - 50k Ω , or 0 - 100k Ω ; 128 steps
- Maximum output resistance: nominal value +/- 30%
- Maximum wiper current: 1mA
- Approximate wiper resistance: 100 Ω (MPA-10k); 500 Ω (MPA-100k)
- Minimum voltage on potentiometer terminal: 0V
- Maximum voltage on potentiometer terminal: 5V

MIDI-Controlled Digital Logic

- Maximum source/sink current per output: 25mA

7.2 Output Wiring

Each MPA potentiometer output behaves as a standard mechanical-control potentiometer. See Figure 7.1.

Figure 7.1: MIDI-Controlled Potentiometer Equivalent Output Schematic

